

910/910R GPS Controlled Frequency Standards

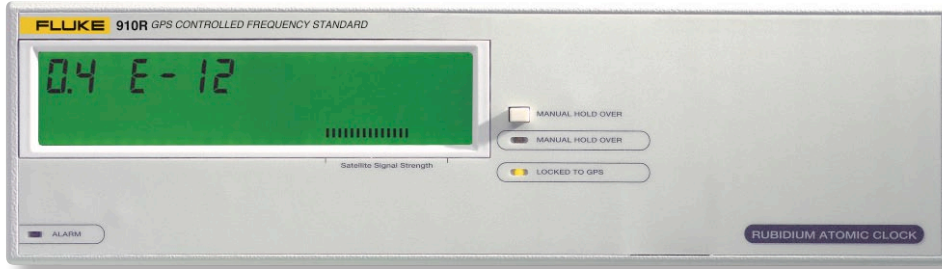

The cesium controlled frequency standard that uses GPS technology and connectivity to provide primary standard traceability from any location

The 910 and 910R GPS-controlled frequency standards deliver a precision frequency and pulse-per-second time “reference which, with its many connectivity options, can be installed, monitored and managed from virtually any location. Both models receive their long-term frequency stability from the built-in cesium standards in the GPS-satellite array, yet can also provide a very high short-term stability from the built-in oven controlled crystal oscillator (OCXO) or rubidium oscillator (Rb).

Both the 910 and 910R are fully traceable and extremely accurate frequency standards and are ideally suited for use in many applications, including telecommunications, calibration and automatic test systems.

Unique traceability feature means no more re-calibrations

Off-air frequency standards have existed for several years. But until now, they all have had the same internal architecture (Figure 1). The unit is, in effect, a “black box,” with an antenna input and a frequency output.

The local oscillators control process (disciplining) is hidden

from the user. Typically, users have used another frequency reference (for example, a rubidium standard), a timer/counter and a PC for logging the deviation between the “black box” and the frequency reference.

The concept of traceability requires an unbroken chain of comparisons to international standards, on a continuing basis, where all comparisons produce documented results with stated uncertainty.

Now, for the first time, a documenting frequency comparator and a very stable secondary standard are united within the same instrument together with the GPS receiver.

The received GPS signal is measured continuously against the local oscillator. Phase and frequency deviation is stored

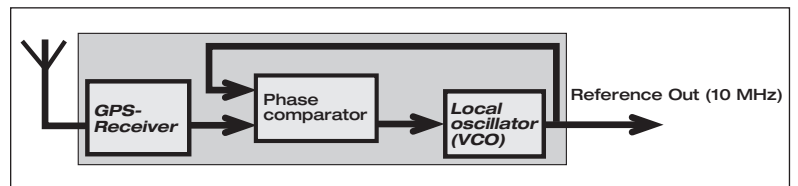

Figure 1. A typical “black box GPS receiver” (antenna in - reference out). Internal oscillator offset and adjustments are invisible to the user.

Technical Data

internally and can at any time be transferred to any PC directly from the 910/910R or, via the optional Ethernet interface, from or to almost anywhere. Then by using the GPSView™ software supplied with every model, a printout of the traceability record can be obtained. The unbroken calibration history chain—day by day—is maintained in the non-volatile memory for several years, with the current 24-hour mean offset being displayed continuously on the front panels LCD display.

Such unique traceability to primary standards means that the 910 and 910R never need to be away for re-calibration. Thanks to this design, the very high stability built-in rubidium or OCXO oscillator is continuously calibrated to the primary frequency standards in the US Naval Observatory and ultimately to UTC, in both operating modes, disciplined or manual hold-over.

Two high-stability models to meet your application, and fit your budget

Fluke offers two standard models in its controlled frequency standards range; the very-high stability 910R with its built-in rubidium atomic clock as the local oscillator, and the affordable 910 with its high stability local oven controlled crystal oscillator.

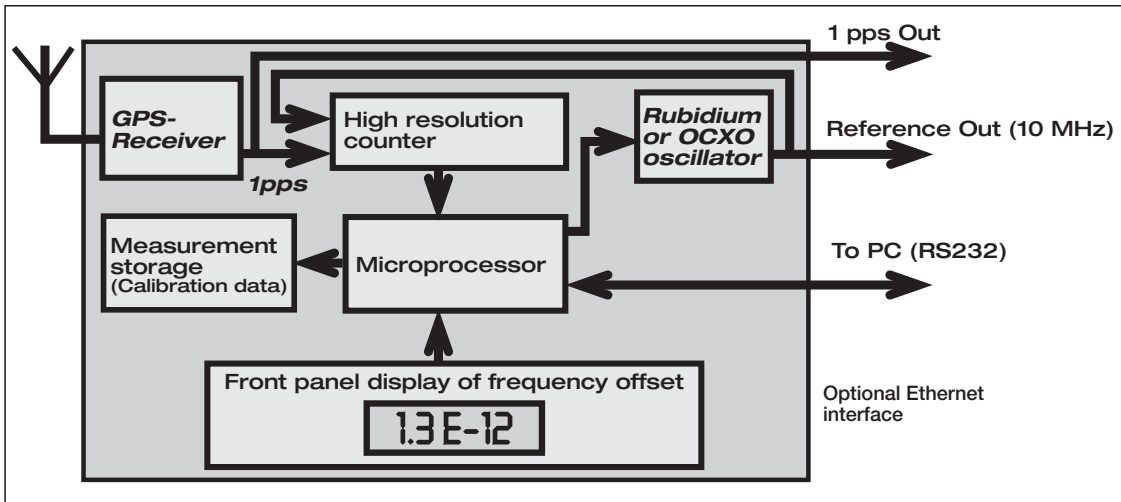

Figure 2. The Fluke 910 and 910R have built-in comparison between the GPS receiver and the internal oscillator. The frequency offset is displayed and stored and a traceability record can be produced at any time.

Up to 13 outputs, maximizing cost efficiency

Both models come with one 5 MHz and five 10 MHz sinewave outputs as standard. A one pulse-per-second output is also included.

If your application requires more outputs—for example, if several other instruments need to be supplied from the same frequency standard—option 70 allows you to mount five more 10 MHz outputs. Alternatively, option 72 allows you to expand your instrument to give five extra 2.048 MHz outputs, which is particularly useful in many telecoms applications. Option 73 provides five extra 13 MHz outputs, the standard frequency for GSM base station master clocks. Another variant on output configuration is offered through option 71, which gives the instrument an additional four sine wave outputs of 10 MHz, 5 MHz, 1 MHz and 0.1 Hz, plus a 0.1 MHz square wave output.

And finally, option 75 allows you to define your own pulse frequency output.

Central or remote monitoring, management and data collection, using the 910/910R Ethernet-port

The 910 and 910R can both be fitted with an optional Ethernet communication interface (option 76) which enables on-line access. Using the GPSView™

software supplied, it is possible to monitor both instrument and GPS status, or even collect calibration data, via the internet or any Local Area Network.

With Ethernet interface connectivity, distances to which data can be transmitted become unlimited, unlike that of any standard GPIB or RS-232 interinterface, thereby allowing the 910/910R to be monitored from practically anywhere.

This means that the metrologist or lab technician no longer requires a ‘floating’ laptop PC to directly perform instrument management tasks, as this can now be achieved from any desktop PC, from any location inside or outside the calibration laboratory. It also allows data from multiple instruments to be simultaneously viewed in real time.

Two high-stability operating modes to suit your application

Most users prefer automatic adjustment (known as disciplining) of their frequency standard, to fully eliminate long-term frequency changes (aging). This disciplined mode is also the default mode in the 910 and 910R. As long as there is a valid satellite signal, the internal local oscillator is monitored and adjusted and the mean 24-hour frequency offset is always virtually zero. However, in this mode, the inherent short-to-medium term stability of all local

oscillators, except rubidium, is compromised. This is true for all GPS frequency references. The received GPS signal has relatively large short-term frequency variations, due to variations in atmospheric conditions. This means that when using the received GPS signal for disciplining the 910 (OXCO), the stability is reduced a little for averaging times of 100 s to 1000 s.

In this mode, the frequency deviation between the internal timebase oscillator and the received GPS-signal is used to continuously adjust the oscillator (disciplining). The resulting frequency offset and adjustment data is stored in non-volatile memory every 24-hours, to enable printout of the traceability record. The actual frequency offset (24h mean value) is calculated and displayed on the front panel.

Some applications demand superior short-medium term stability, especially for jitter and wander measurements in digital telecommunication networks.

The unique manual hold-over mode makes it possible to switch over temporarily from disciplined to hold-over mode during the actual measurement, thereby achieving a superior frequency accuracy at the start of the measurement and a superior stability through the measurement.

Here, the internal oscillator is not adjusted. This mode is normally automatically entered when there is no usable received

GPS-signal. This mode can also be selected manually by activating the Manual Hold-Over Key. If Manual hold-over is set together with a valid received GPS signal, the actual frequency offset is calculated, displayed and stored in non-volatile memory every 24-hours.

For the ultra-stable rubidium oscillator in the 910R, there is no measurable difference between the stability in disciplined and hold-over mode, for averaging times up to 1000 s.

Designed for portability too

When using manual hold-over mode, the 910 or 910R act as a stand-alone OCXO or rubidium frequency standard. This means that one typical drawback of a GPS receiver, lack of portability, is eliminated. A typical GPS receiver needs hours to lock after a change of location, whereas the 910 and 910R are up and running after just ten minutes.

GPSView Software

GPSView is a Windows 95/98/2000/NT program that communicates with the GPS-controlled frequency standard. Its main purpose is to provide a traceable calibration document based on the 24-hour frequency offset values, internally stored in the non-volatile memory of model 910/910R (Figure 3).

It is only necessary to download data to a PC to the 910/910R once every second year to obtain an unbroken traceability chain since first use. For performance analysis over a shorter period and for short-term phase variation, data can be obtained over the latest forty-day period.

From GPSView, the user can control the operating mode (Disciplined or Hold-Over), and lock the front panel to prevent unintended change via the Manual Hold-Over Key. The user can also set the optional pulse output frequency and duty cycle.

910R (GPS-Rb)

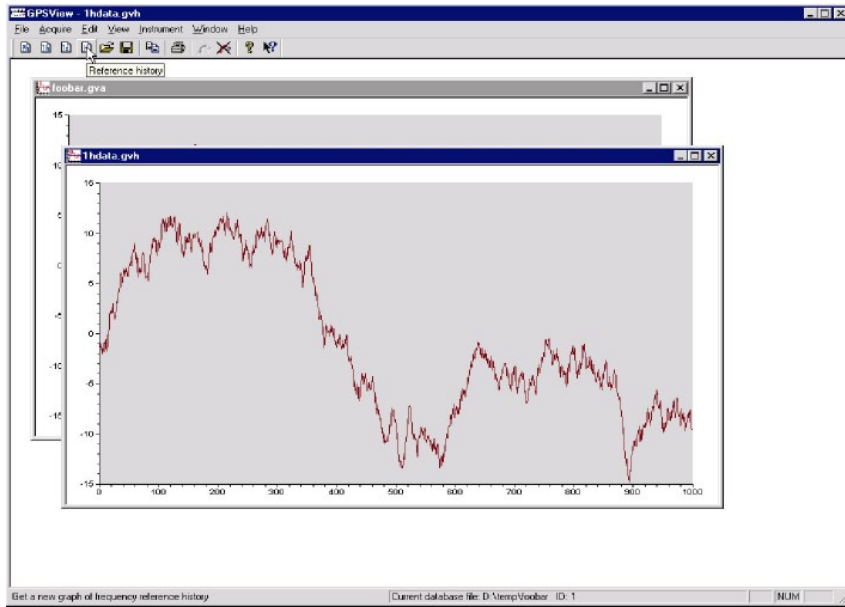

Figure 3. GPSView can print a calibration protocol at any time.

910/910R specifications

Frequency stability - locked to GPS

Frequency offset (24h mean):

< 1 x 10⁻¹²*

Short term (Allan dev.):

< 1 x 10⁻¹² (τ = 1000 s)

< 3 x 10⁻¹² (τ = 100 s)

< 1 x 10⁻¹¹ (τ = 10 s)

< 3 x 10⁻¹¹ (τ = 1 s)

Warm up (+25 °C): 20 mins to lock

*At temperature 23 °C ± 3 °C

Frequency stability - Hold-Over

Aging/24h: < 2 x 10⁻¹² (typ.)

Aging/month: < 5 x 10⁻¹¹

Temp. (0 °C to +50 °C): < 3 x 10⁻¹⁰

Temp. (23 °C ± 3 °C): < 2 x 10⁻¹¹ (typ.)

Short term (Allan dev.):

< 3 x 10⁻¹² (τ = 100 s)

< 1 x 10⁻¹¹ (τ = 10 s)

< 3 x 10⁻¹¹ (τ = 1 s)

Warm up (+25 °C): 10 minutes to 4 x 10⁻¹⁰

Phase noise

Offset

1 Hz

10 Hz

100 Hz

1 kHz

10 kHz

100 kHz

Phase noise

-80 dBc/Hz (typ.)

-90 dBc/Hz (typ.)

-130 dBc/Hz (typ.)

-140 dBc/Hz (typ.)

-140 dBc/Hz (typ.)

-145 dBc/Hz (typ.)

locked to GPS

*Frequency offset (24h mean):

< 2 x 10⁻¹²

Short term (Allan dev.):

< 5 x 10⁻¹¹ (τ = 1000 s)

< 3 x 10⁻¹¹ (τ = 100 s)

< 5 x 10⁻¹² (τ = 10 s)

< 5 x 10⁻¹² (τ = 1 s)

Warm up (+25 °C): 20 mins to lock

*At temperature 23 °C ± 3 °C

Frequency stability - Hold-Over

Aging/24h: < 3 x 10⁻¹⁰

Aging/month: < 3 x 10⁻⁹

Temp. (0 °C to +50 °C): < 2.5 x 10⁻⁹

Temp. (23 °C ± 3 °C): < 4 x 10⁻¹⁰ (typ.)

Short term (Allan dev.):

< 1 x 10⁻¹¹ (τ = 100 s)

< 5 x 10⁻¹² (τ = 10 s)

< 5 x 10⁻¹² (τ = 1 s)

Warm up (+25 °C): 10 minutes to 5 x 10⁻⁹

Phase noise

Offset

1 Hz

10 Hz

100 Hz

1 kHz

10 kHz

100 kHz

Phase noise

-100 dBc/Hz (typ.)

-120 dBc/Hz (typ.)

-130 dBc/Hz (typ.)

-135 dBc/Hz (typ.)

-135 dBc/Hz (typ.)

-135 dBc/Hz (typ.)

910 (GPS-OCXO)

Frequency stability -

Common

Reference outputs (BNC)

10 MHz: Sine wave, 0.6 V rms into 50 Ω

5 MHz: Sine wave, 0.6 V rms into 50 Ω

1 pps: TTL-levels; low < 0.4 V, high > 2 V into 50 Ω load.

Pulse output (opt. 75): TTL-levels; low < 0.4 V, high > 2 V into 50 Ω load

10 MHz and 5 MHz outputs

Freq. stability: See frequency stability specs for 910 and 910R

1-pps output (locked to GPS)

Duty cycle: Approx. 20 %

Jitter: < 60 ns rms relative to UTC or GPS (position hold, SA on)

5 additional 10 MHz outputs (option 70)

See specification for 10 MHz above

Multiple reference outputs (option 71)

Sine wave outputs: 10, 5, 1 and 0.1 MHz > 1 Vrms into 50 Ω

Pulse output: 0.1 MHz; > 3 Vp-p into 50 Ω
0 V ≤ LO < 0.8 V, 3 V < HI ≤ 5 V

5 additional 2.048 MHz outputs (option 72)

Frequency: 2.048 MHz square wave

Output level: -1.2 V to +1.2 V ± 10 % into 75 Ω (G.703:10)

Jitter: < 0.01 UI

5 additional 13 MHz outputs (option 73)

Output signal: TTL (symmetrical)

Typical levels into 50 Ω:

High voltage: 2.35 V

Low voltage: 0 V

Jitter: < 0.01 UI

Long term stability: Same as main reference

Pulse output (option 75)

The frequency and duty cycle are set via the included PC-program

Selectable frequency: N * 10⁻⁷ Hz;

N is an integer

Factory default setting: 1 Hz

Jitter: < 500 ps rms

Freq. stability: See frequency stability specs for 910 and 910R

Ethernet interface (option 76)

Communication port:

Connector: RJ45

Protocol: 10Base-T

Buffer RAM: 1 kbit

Configuration port:

Connector: Dsub9, RS-232

Internal data storage

24h-freq. offset: two-years data, non-volatile memory

Adjustment data: two-years data, non-volatile memory

Phase data (TIE): 40-days data, volatile memory

LED indicators

Locked to GPS, Alarm, Manual Hold-Over

Display indicators

7-segment area:

24h mean freq. offset (if valid data exist)

Time of day (if GPS gives valid time)

“910” or “910R” (if GPS contact not sufficient)

Alarm text (plus Alarm LED)

REMOTE segment: Local lock-out (from PC)

Analog bar graph: Satellite signal strength

GPS-receiver

Antenna connector: Type N

Channels: 8, parallel tracking

Carrier, code: L1, C/A

Antenna (option 01)

Type: Active L1

Operating temp.: -40 °C to +70 °C

Height: 81 mm (3.2 in) (excl.connector)

Weight: 230 g (8 oz)

Gain: > 30 dB

Connector: TNC

Antenna cable (option 02/20, option 02/50)

Type: RG213

Length: 20 m (02/20), 50 m (02/50)

Connectors: N-type and TNC (male)

Cable delay: 101 ns (02/20), 251 ns (02/50)

Attenuation:

Approx. 8 dB at 1.6 GHz (02/20)

Approx. 20 dB at 1.6 GHz (02/50)

PC-connection

Interface: RS-232, DTE

Environmental

Temperature: 0 °C to +50 °C (operating)

-40 °C. to +70 °C (storage)

Safety: Compliant to CE: EN

61010-1 + A1 (1992) + A2 (1995)

EMI: Compliant to CE: EN 61326-1 (1997)

Power consumption

Line voltage: 100 V to 240 V (± 10 %)

Line frequency: 47 Hz to 63 Hz

Power 910R: < 75 W at warm-up

< 35 W continuous operation

Power 910: < 25 W at warm-up

< 12 W continuous operation

Dimensions (WxHxD)

315 mm x 86 mm x 395 mm

(12.4 in x 3.4 in x 15.6 in)

Weight

910R (net) 4.4 kg (9.7 lb)

910R (shipping) 7.4 kg (16.3 lb)

910 (net) 3.9 kg (8.6 lb)

910 (shipping) 6.9 kg (15.2 lb)

Ordering information

910	GPS-Controlled OCXO Frequency Standard. 5 x 10 MHz and 1 x 5 MHz outputs
910R	GPS-Controlled Rubidium Frequency Standard. 5 x 10 MHz and 1 x 5 MHz outputs
910X-70	5 additional 10 MHz outputs
910X-71	Multiple reference outputs - 0.1 MHz, 1 MHz, 5 MHz and 10 MHz sinewave outputs, plus a 0.1 MHz squarewave output
910X-72	5 additional 2.048 MHz outputs
910X-73	5 additional 13 MHz outputs
910X-75	1 additional pulse output 0.5 Hz...5 MHz
910X-76	Ethernet interface

Included accessories

Operators manual, GPSView Software

Optional accessories

PM9622/00	Rack Mount Kit
PM9627	Carrying Case
PM9627H	Heavy Duty Aluminium Carrying Case
910X-01	GPS Antenna
910X-01/50	GPS Antenna Mounting Kit
910X-02/20	Antenna Cable, 20 m
910X-02/50	Antenna Cable, 50 m
910X-02/130	Antenna cable, 130 m

Various options for calibration certificates are available; contact your local Fluke sales representative for details.

Fluke. Keeping your world up and running.®

Fluke Corporation

PO Box 9090, Everett, WA USA 98206

Fluke Europe B.V.
PO Box 1186, 5602 BD
Eindhoven, The Netherlands

For more information call:
U.S.A. (800) 443-5853 or
Fax (425) 356-5116
Europe/M-East/Africa (31 40) 2 678 200 or
Fax (31 40) 2 678 222
Canada (800) 36-FLUKE or
Fax (905) 890-6866
Other countries (425) 356-5500 or
Fax (425) 356-5116
E-mail: fluke-info@tc.fluke.com
Web access: http://www.fluke.com

©2000, 2003, 2008 Fluke Corporation.
Windows and NT are registered trademarks
of Microsoft Corporation. Printed in U.S.A.
03/2008 1567182 D-ENG-N Rev C
Pub_ID: 10780-eng Rev 02

Printed on recycled paper.